

Please thoroughly read through these Operating Instructions including the safety instructions before using the lashing strap for the first time!

Dear SpanSet Customer,

Congratulations on purchasing a SpanSet lashing strap! You have chosen a quality product guaranteed to last long when properly used. These Operating Instructions contain a general description of the correct use of the strap with reference to the applicable standards and laws. Please read through the entire Operating Instructions before using for the first time! Should you still have any questions, please contact the SpanSet dealership where you purchased your SpanSet lashing strap. Besides a wide range of lashing straps, SpanSet also offers all the accessories for securing loads, along with other products for lifting and for personal protective equipment.

Your SpanSet Group

## General Operating Instructions

1. Single/two-part lashing straps
2. Handling load-securing equipment
3. Using the lashing strap
4. Inspection, testing and repairs
5. Storage
6. Basic and advanced training

### 1. Single/two-part lashing straps

The lashing strap consists of the:

- a) belt or webbing
- b) tensioning device
- c) end fittings/fasteners

The **single-part lashing strap** consists of the webbing and the tensioning device and is generally used for strapping the load.

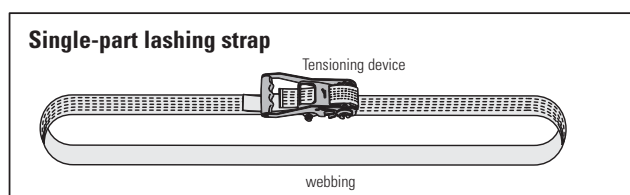

The **two-part lashing strap** consists of a fixed end, permanently connected to the tensioning device, the tensioning device and the loose end, which is the adjustable length and is threaded into the tensioning device.

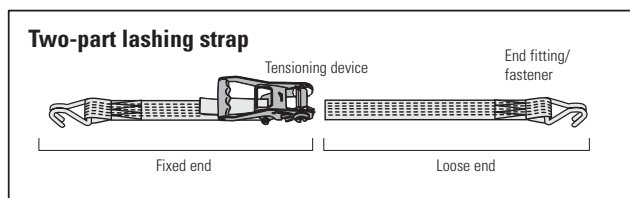

**Re a)** The webbing is manufactured from the fibre material polyester (PES, blue label), polyamide (PA, green label) or polypropylene (PP, brown label). Lashing straps are typically available in lengths of 4, 6, 8, 10 and 12 m.

**Re b)** The tensioning device consists of the frame with the centrally slotted spindle and

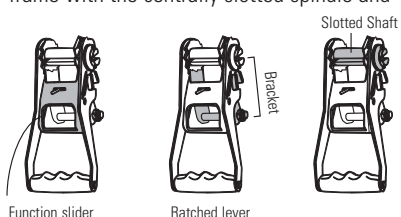

### Applicability

Securing loads on commercial vehicles is necessary in order to protect the lives and health of people and animals and to avoid damage to the cargo. These Operating Instructions describe the selection, handling, use, checking and documentation and withdrawal conditions of reusable lashing equipment according to DIN EN 12195 Part 2. The relevant guidelines and standards on securing loads basically apply to the safe and reliable transport of cargo by land, sea and air.

The hazards that can arise in the proper use of lashing equipment are described in DIN EN 12195 ff. In addition, other regulations may apply, for example when transporting dangerous goods or in rail or ship transportation. Appendix B to the specified standard contains the fundamentals for the manufacturers' operating instructions on the use and care of lashing equipment.

### Safety information

In selecting and using lashing equipment you must consider the required lashing force, the mode of use and the type of cargo to be lashed. The size, shape and weight of the cargo as well as the intended mode of use, the transport environment (vehicle suitability, lashing points) and the type of cargo determine the correct choice.

### Important:

When securing the cargo, note the dynamic forces occurring when setting off, braking, cornering, etc. For correctly dimensioning the cargo securing equipment you have to know these forces and plan the use of the lashing straps accordingly. SpanSet offers regular training programs and seminars for conveying the necessary know-how. In addition, SpanSet provides aids for facilitating cargo security. The software "ZurrSoft" and the lashing force calculator from SpanSet are aids for calculating the necessary tensile and initial tension forces as well as the number of lashing straps. For stability reasons, at least two lashing straps must be used for lashing down and two pairs of lashing straps used for diagonal lashing, if no other measures are employed for preventing twisting or slipping of the cargo through (e.g.) positive locking.

Particularly important for cargo securing is friction. The friction acts between the cargo and the loading surface and depends on the material and the surfaces. By using the SpanSet Anti-Slip Mat you can achieve a guaranteed coefficient of sliding friction. The selected lashing equipment must be strong enough for the intended purpose and have the correct length for the type of lashing.

Responsible users plan cargo security in advance: they plan the attachment and removal of the lashing devices before the start of the journey. With longer trips, partial unloading must be considered. Calculate the number of lashing devices according to EN 12195-1 or VDI 2702 (sources of supply are stated at the end of the Operating Instructions).

Only lashing systems labeled for lashing down with STF (standard tension force) may be used for friction lashing. Because of different characteristics (e.g. one lashing chain in combination with a lashing strap) and because of different extension characteristics, only identical lashing device combinations may be used in parallel for lashing the same load. When using additional fittings and lashing devices, make sure that they fit the lashing equipment.

**Opening the lashing:** Before opening, make sure that the cargo is stable even without being secured and does not endanger unloading personnel by falling down. If necessary, attach blocking devices to the cargo beforehand that have been planned for further transport, in order to prevent the load falling. Before starting to unload, you must loosen the lashing until the load is free.

**The SpanSet product line also contains lashing straps with the ABS system (see section 3: Using the lashing strap/ABS system).**

### Note:

**The SpanSet product range also contains lashing straps based on the ABS system. The ABS system allows the pre-tension to be relaxed in small steps when loosening the lashing strap (see section 3: Using the lashing strap/ABS system). The webbing tension can then be gradually decreased.**

the ratchet handle. By moving the ratchet handle to and fro, turn the slotted spindle until the webbing is wound up and the lashing strap tensioned. Releasing and moving the ratchet handle to the loose position (see 3.f.) releases the slotted spindle lock.

The webbing tension is relaxed and the strap can be removed from the load.

**Re c)** The end fittings serve to fasten the lashing strap onto the vehicle body. A variety of different fittings are available that

are suitable for the different kinds of vehicles, such as J hooks, rave hooks, flat hooks, snap hooks, etc.

### 2. Handling the load securing equipment

**2.1** The lashing strap should only be used by suitably trained personnel.

**2.2** Lashing straps must never be used for lifting loads or for any other purpose for which they are not intended.

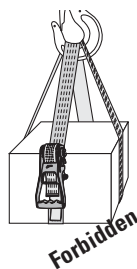

**2.3** Avoid using the strap in the presence of chemicals such as acids or alkalis! Use of the lashing equipment in combination with chemicals is permitted only by agreement with the manufacturer, with reference to the duration and conditions of use. The following information will be required:

- Chemicals
- Concentrations
- Temperature
- Dwell time

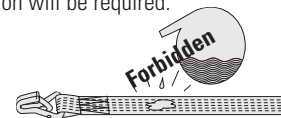

Lashing equipment coming in contact with acids, alkalis or other aggressive agents should be rinsed with water and cleaned prior to storage or reuse. Ask the manufacturer about further cleaning procedures.

**2.4** Tensioning devices should be regularly cleaned and lightly lubricated in the vicinity of the sprockets (be sure not to lubricate the places to which the belt is applied; the belt can otherwise slip through and release the load).

**2.5** If you plan to use the lashing equipment in areas with extreme temperatures, ask the manufacturer about additional instructions. Lashing equipment bearing a green or blue label may be used in a temperature range of -40°C to +100°C (PES/PA) or 40°C to +80°C (PP) without any problems.

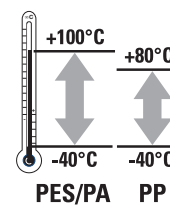

**2.6** Use only load-securing equipment bearing a label. Unidentified lashing equipment with illegible or missing labels must be withdrawn from use!



**2.7** Only lashing systems which are shown to be suitable by means of indication of the STF (standard tensioning force for possible pretensioning) on the label may be used for lashing down. The STF is applied to the system by the manual force which is likewise stated on the label.

**Warning! The functioning of the lashing equipment can no longer be guaranteed if these especially important instructions are disregarded. Serious accidents leading to injury or even death are possible as a consequence.**

■ Lashing equipment must not be overloaded, since overloading will lead to breakage of or damage to the lashing equipment.



■ Do not use lashing equipment for stopping purposes, since it is not designed for this use.



■ Never knot lashing equipment, since considerable loss in strength can result.

■ Lashing equipment should not be driven over by loads. This can damage the lashing equipment.



■ Do not crush lashing equipment. This can result in considerable loss of strength.

■ Damaged, overloaded or worn lashing equipment must be immediately withdrawn from service. In these cases the strength of the lashing equipment can no longer be ensured.

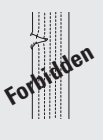

■ When diagonally lashing, tension the lashing strap only to remove the slack from the system and apply a positive restraint. Do not attempt to apply pre-tension otherwise overloading of the lashing equipment may occur.

In the case of lashing straps designed for lashing loads down and which has the standard tension force (STF) shown on the label, no more than the standard hand force (SHF) shown on the label may be applied. This is normally 20 daN for a strap width of 25 mm and 50 daN for all other belts. Lashing straps may only be tensioned by hand and with no aids to prolong the lever (rods, pipes, etc.). If this is ignored the strap may be overloaded and there is a risk of acute danger!

■ Use only lashing equipment that is not twisted (tensioning)



■ Lashing hooks must not be loaded at their tips unless the hooks are specially designed for this purpose, since the hooks are generally not designed for this purpose; otherwise the lashing equipment will no longer be functional. Lashing hooks should have locks. To avoid detachment of a lashing hook without a lock in a lashing point on the loading surface, suspend from the inside outwards.



■ To avoid stress on tensioning devices and fasteners, do not lay them across edges, otherwise they may fracture. Tensioning devices operating according to the winding principle must not be subjected to less than 1.5 or more than 3 turns of the clamping device (webbing) (for ABS ratchets, see section 3.d.: Using the lashing strap), since with less than 1.5 turns the belt can slip through and with more than 3 turns crushing of the belt begins. In both cases functioning is no longer ensured. Lashing equipment must no longer be used after fracture or deformation of a fastener or a part of a tensioning device, since the functioning of the lashing equipment is no longer ensured.

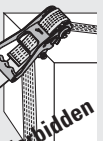

■ Lashing equipment must not be clamped across sharp edges and must not be pulled across sharp edges, since otherwise the webbing will be cut through. A sharp edge occurs if the edge radius „r“ is less than the cross-section „d“ of the belt.

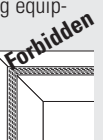

■ After traveling a short distance and during the entire trip, check the initial tension of the lashing equipment, especially in the case of lashing down, and if necessary retension, since the load settles during travel, causing a loss in initial tension (securing force).

■ Heed the co-applicable documentation and manufacturer's instructions to help prevent accidents.

### 3. Using the lashing strap

#### a. Lashing equipment basic position / initial position

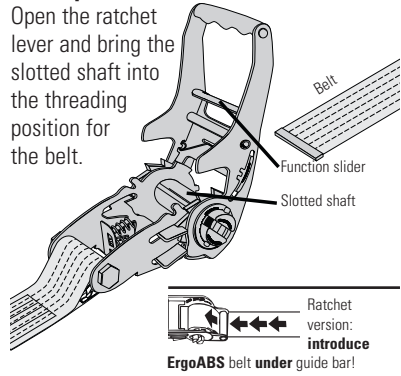

#### b. Attaching the lashing strap

Place the belt on the cargo and securely suspend the fastener at the lashing point.

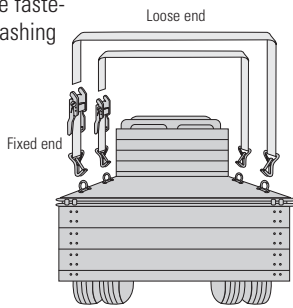

#### c. Length adjustment of the lashing equipment

Thread the loose end in the slotted shaft and pull through until the belt lies taut against the cargo.

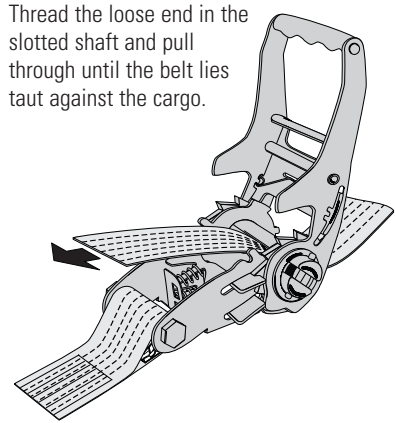

#### d. Tensing the lashing equipment

Tighten until the desired tension is attained. You must wind at least 1.5 times (**ratchets with ABS system: at least 2 turns**) but at most 3 times on the slotted shaft. Tensioning devices with tension force indicators show the applied initial tension force. This combination is recommended for lashing down.

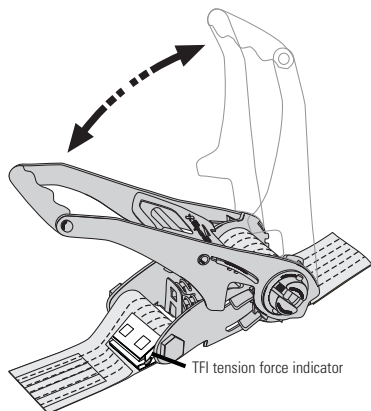

With push ratchets the belt is tensioned by pushing up and with **pull ratchets** (e.g. ErgoABS) by pulling down the ratchet handle.

#### e. Locking the tensioning device

After lashing, pull the function slider and position the ratchet handle into the close position until the slider can engage in the lock recess. The ratchet is now closed.

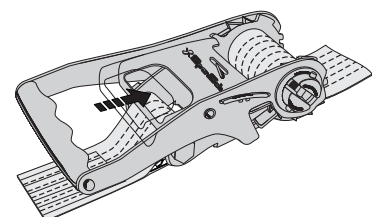

#### f. Releasing

Pull the function slider and swing the ratchet lever through 180° up to the limit stop, to let the slider engage in the end recess. **Warning! The initial tension is released with a jolt.**

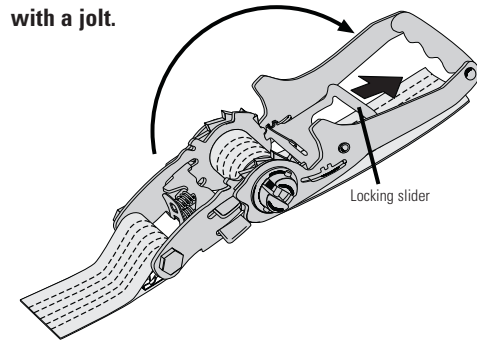

#### Special features of lashing straps with ABS system

The SpanSet ratchet lashing straps with the ABS system allow release of the initial tension in small stages when the belt tension is relieved by the anti-belt slip procedure. Move the ratchet lever into the release range. Rocking the ratchet handle to and fro releases the initial tension gradually. Opening the ratchet handle into the maximum position makes the slotted shaft rotate freely, and the webbing can be easily pulled out.

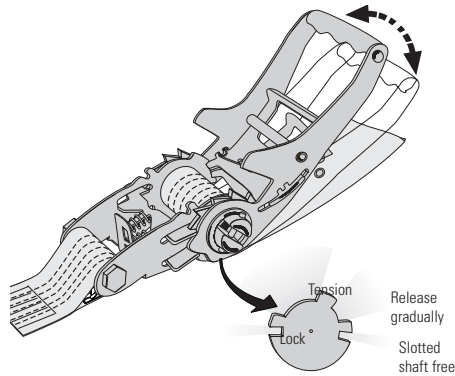

#### TFI tension force indicator

ErgoABS lashing straps are fitted with the **TFI, Tension Force Indicator**, as standard. The TFI indicates the attained pre-tension force. You can read off the attained pre-tension force either on the left side, 250 and 500 daN, or on the right side, 750 daN. Knowledge of the actual tension force allows precise securing of the cargo. The required number of lashing straps can then be determined and the labour time.

#### Reading off the initial tension force with the TFI:

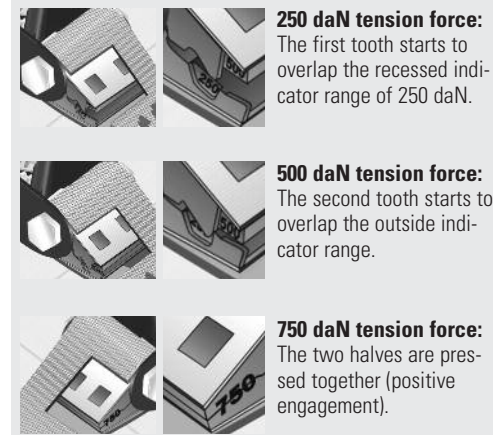

#### Special features of cambuckle straps

Pull in the webbing from the rear side of the **cambuckle** and tension the strap with one hand. To loosen, press on the lock of the **cambuckle** and the belt is.

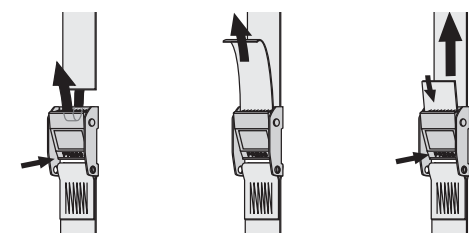

SpanSet GmbH & Co. KG  
Jülicher Strasse 49-51  
D-52531 Übach-Palenberg  
Germany  
Telephone +49 (0) 2451 4831-0  
Fax +49 (0) 2451 4831-207  
e-mail: info@spanset.de  
Internet: www.spanset.de

SpanSet AG  
Eichbühlstrasse 31  
CH-8618 Oetwil am See  
Switzerland  
Telephone +41 (0) 1-929 70 70  
Fax +41 (0) 1-929 70 71  
e-mail: info@spanset.ch  
Internet: www.spanset.ch

D003406X - TOP ART

## General Operating Instructions

### Handling of lashing straps for cargo securing

#### Marking

Illegible data on the label.  
Missing label.

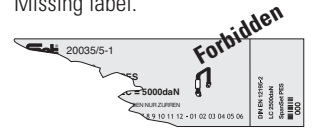

### 4. Inspection, testing and repair

While using the lashing straps note any visible defects. If you find any defects affecting safety, you must remove the lashing strap from further service.



This applies especially to

- superficial tears, transverse tears, notches, fractures and corrosion of the tensioning device or fasteners
- widening by more than 5 % of the hook opening or deformations in general.

Periodic inspection by a responsible person must be performed according to a schedule specified by the contractor, but at least once a year. Depending on the conditions of use and the operational conditions, other inspections by a responsible person may be required in the interim.

#### Criteria for withdrawal from use for lashing straps

Lashing straps must no longer be used if the following deficiencies are present:

#### Webbing

Incisions greater than 10 % at the web edge or excessive wear, since repair is then no longer possible. Damage to the seams. Deformation from heat. Contact with aggressive substances, if not expressly approved by the manufacturer (see section 2.3).

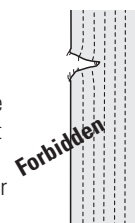

#### Tensioning devices

Deformation of the tensioning element at the slotted shaft or of the locking slider, wear of the sprockets or broken ratchet handle.

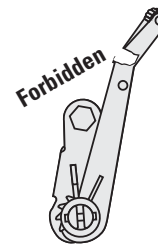

#### End Fittings

Widening of the hook by more than 5 %. Cracks, fractures, considerable corrosion, permanent deformation.

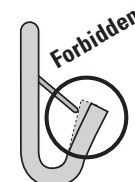

### 5. Storage

Care and proper storage of the lashing strap will maintain the high quality and functionality of your SpanSet product over a long period of time. After each use, examine the lashing strap for possible damage and dirt and rectify these problems before storing the strap. Keep the lashing straps clean, dry and well ventilated when storing, and avoid direct exposure to sunlight and chemicals. After longer periods of storage, check the lashing strap for full functionality.

### 6. Basic and advanced training

While there is growing awareness about good and safe cargo securing, the general legal constraints and knowledge about the safe transportation of cargo are constantly changing. You should therefore have your employees undergo basic and advanced training in cargo securing. SpanSet offers regular seminars on **lifting, lashing and height safety**.

Of course, we also offer this training on site. Call us for further information!



Please also note the SpanSet line of accessories for cargo securing technology:

- Edge protection products
- Anti-slip mats
- Cargo securing video
- Lashing force calculator
- ZurrSoft, the software for calculating lashing forces
- Delog, pre-tension indicator
- TFI, tension force indicator

#### Source of supply for EN and VDI standards and specifications:

British Standards Institution • 389 Chiswick High Road • GB-London W4 4AL  
Tel +44 208 996 90 00 • Fax +44 208 996 74 00